

Xiria 3.6-24 kV Medium Voltage Ring Main Unit

Application Guide Xiria



EATON

Powering Business Worldwide



Automotive



Aerospace



Truck



Hydraulics



Electrical

Powering business worldwide

Eaton delivers the power inside hundreds of products that are answering the demands of today's fast changing world.

We help our customers worldwide manage the power they need for buildings, aircraft, trucks, cars, machinery and entire businesses. And we do it in a way that consumes fewer resources.

Next generation transportation

Eaton is driving the development of new technologies – from hybrid drive trains and emission control systems to advanced engine components – that reduce fuel consumption and emissions in trucks and cars.

Higher expectations

We continue to expand our aerospace solutions and services to meet the needs of new aviation platforms, including the high-flying light jet and very light jet markets.

Powering Greener Buildings and Businesses

Eaton's Electrical Group is a leading provider of power quality, distribution and control solutions that increase energy efficiency and improve power quality, safety and reliability. Our solutions offer a growing portfolio of "green" products and services, such as energy audits and real-time energy consumption monitoring. Eaton's Uninterruptible Power Supplies (UPS), variable speed drives and lighting controls help conserve energy and increase efficiency.

Building on our strengths

Our hydraulics business combines localised service and support with an innovative portfolio of fluid power solutions to answer the needs of global infrastructure projects, including locks, canals and dams.



MV Switchgear Technology is in our DNA

Eaton's knowledge and understanding of industries, applications, technology and products enables us to offer customers safe, reliable and high performance solutions. We have been part of the Medium Voltage switchgear technology creation and therefore carry what's needed with us – always!

Complete MV switchgear solutions

The series of Eaton Medium Voltage systems offers switchgear and components for applications in distribution networks (substations and transformer stations) and industrial power supplies. These technically high quality systems are air or epoxy resin insulated and are always equipped with circuit-breakers based on proprietary vacuum interrupters.

The medium voltage switchgear systems carrying Eaton's brand are based on the use of vacuum circuit-breakers combined with solid insulation material. This is an environmentally-friendly technology in comparison with the methods used by many other suppliers, which use SF₆ as an insulation medium.

Eaton thus has a wide range of switching systems and components that offer an environmentally friendly solution for every application. Additionally, Eaton's global service network provides maximum customer support in all regions of the world.

Industry leading vacuum and solid insulation technology

Through more than eighty years of innovation and experience, Eaton has developed environmentally friendly vacuum interrupters capable of reliably switching both normal load currents and high stress fault currents.

Eaton is one of the few companies in the world producing vacuum interrupters and has succeeded in developing world class products with a number of international patents. This has been achieved through company acquisitions over the years of Westinghouse, Cutler-Hammer, MEM and Holec.

To increase the dielectric strength of the vacuum interrupter, Eaton has also designed vacuum interrupters that are encapsulated in epoxy resin material. The medium voltage IEC circuit breaker family utilizes this solid insulation technology that has been catering to a wide range of applications for more than 40 years.

Eaton's range of
SF₆ free switchgear
for Medium Voltage



Administrative data

Issue number:	605 6243 G01 01
Date of issue:	06-10-2010
Translation of:	-

Authorised by

Job title:	Product Manager
Name:	A.R.A. Pikkert
Date:	
Initials:	

Table of contents

Application Guide Xiria

1. GENERAL DESCRIPTION.....	6	5.3. Busbar system.....	22
1.1. Maintenance-free.....	7	5.4. Circuit-breakers	22
1.2. Intrinsically safe	7	5.5. Load break switches.....	23
1.3. Compact	7	5.6. Remote control options.....	23
1.4. Ready for automated networks.....	7	5.7. Changing the voltage.....	23
1.5. Clean and green.....	7	6. STANDARDS	24
1.6. Surface treatment	8	7. TARIFF METERING	25
1.7. Mechanism	9	7.1. Xiria M (max. 24 kV)	25
1.8. Remote control	10	7.2. Xiria MA (max. 12 kV).....	26
1.9. Manual operation.....	11	7.3. Secondary compartment	27
1.10. Interlocks	11	8. SHIPPING DATA	28
1.11. Position indication.....	13	8.1. Transport and handling.....	28
1.12. Switchgear compartment.....	14	8.2. Dimensions and weights.....	28
1.13. Cable compartments	15	9. INSTALLATION	29
1.14. Operating conditions.....	16	9.1. Floor plans.....	29
2. GREEN DESIGN	17	9.2. Switch room setup	33
2.1. Supporting Green Switching initiative	17	9.3. Cable connections	35
2.2. Environmental declaration	17	10. APPLICATIONS	39
3. PRODUCT RANGE	18	10.1. Examples of applications.....	39
3.1. Load break switch.....	18	11. ACCESSORIES AND OPTIONS.....	42
3.2. Circuit breaker	19	11.1. Accessories	42
4. VOLTAGE DETECTION	21	11.2. Options	43
4.1. Detection system	21	11.3. Legacy options (still available).....	46
4.2. Electric details	21	12. MAINTENANCE	47
4.3. Testing.....	21	13. QUALITY	48
5. TECHNICAL DATA.....	22		
5.1. General.....	22		
5.2. Classification according to IEC 62271-200..	22		

1. General description

Xiria is the name of a new generation of ring main units from Eaton. They are characterized by their high level of operational safety and are suitable for applications up to 24 kV. Xiria units are also very compact. Xiria units can be supplied in two-, three-, four- or five-panel versions. Both the primary part of the unit and the mechanisms are housed in a fully enclosed housing which protects the system against environmental influences. There is a choice of two basic panel versions in our product range:

- A vacuum load break switch for ring cable connections.
- A vacuum circuit-breaker for protecting transformers and cable connections.

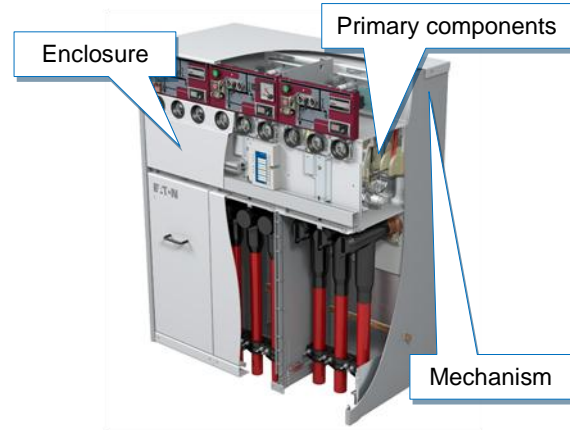

Both versions can be supplied in a unit in any desired combination and order. Xiria is an extremely well designed and modern system. For example, when developing the system we intentionally opted for protection in the form of a circuit-breaker combined with an electronic relay. This is a modern, safe and flexible alternative to fuse protection. In addition it also makes Xiria very easy to use in an automated distribution network. These specific features make Xiria an easy-to-use system that responds perfectly to changing electricity distribution requirements, both now and in the future.

1.1. Maintenance-free



All the live primary parts and mechanisms in a Xiria unit are installed in a fully enclosed housing. This prevents dust, moisture and other environmental influences from affecting the operation of the unit. The switching mechanism has been designed with a minimum number of parts, and is specifically intended for switching after a long period of inactivity – precisely the way it happens in practice. What is more, the mechanism does not use any lubricants, which also benefits its operational safety. As it is maintenance-free, Xiria significantly cuts inspection and maintenance costs without adversely affecting the operational safety of your distribution network. Which is something to look forward to in today's liberalized energy market.



1.2. Intrinsically safe



When carrying out operational actions and work on the cables, it is vital to have unambiguous status indications. When it comes to the safety of the operating personnel, Eaton leaves nothing to chance. That is why Xiria is fitted with directly visible isolation by means of inspection windows in the front which makes the isolating distance between the cable and the busbar system directly visible. A visible, short-circuit proof earthing can take place via the load break switch or circuit-breaker. Xiria is designed with a fully enclosed metal housing combined with singlephase insulation of all primary live parts. This reduces the risk of an internal fault to an absolute minimum, thus providing a high degree of safety and availability. The KEMA-tested arc-proof housing also offers additional protection for operating personnel.

1.3. Compact



Xiria is one of the smallest ring main units of its kind. This high degree of compactness is a direct result of the combination of technologies used by Eaton - electrical field control, solid insulation and the use of extremely compact vacuum interrupters. This compactness offers direct financial benefits in new buildings and when refurbishing existing transformer stations because of the minimal floor area required.

1.4. Ready for automated networks



Xiria is completely ready for use in fully-automated networks. There are various options available for the system, depending on the level of remote signalling and remote control required. These options are modular, so they can be quickly and easily added in the future. In this way Xiria anticipates future developments in automation and operational control, so you can be sure that you will not be left with control, display and communication standards that are too specific or possibly even obsolete.

1.5. Clean and green



Xiria is made exclusively of environmentally-friendly materials. The insulation medium is clean, dry air and the switching medium is vacuum. Thus Xiria responds to the demand for sustainability in energy distribution. The unit is easy to dismantle at the end of its service life as the materials used are clearly labelled and can be reused. This facilitates recycling and avoids excessive costs and environmental taxes when the unit is decommissioned.



1.6. Surface treatment

The surface treatment of the sheet steel parts is carried out according to the powder coating principle, whereby a thermosetting powder is applied. Before the powder coating is applied, the sheet steel parts are pretreated in a spray tunnel with a combination of degreasing and iron phosphate, cleaning with DI water and passivation.

Mountable parts

Base	epoxy polyester resin
Degree of shine	60-70% according to Lange 60 degrees
Layer thickness	average 80 µm, min. 50 µm
Adhesion	glass test ISO 2409 (Gto)
Elasticity	buckling test ISO 1520 dept 4,2 mm with layer 80 micrometers
Salt spray test	ASTM D1654-92240 after 240 hr. 0 mm under-creepage and after 600 hr. max. 3 mm under-creepage

Enclosure

Base	epoxy resin
Degree of shine	60-70% according to Lange 60 degrees
Layer thickness	average 130 µm, min. 100 µm
Adhesion	glass test ISO 2409 (Gto)
Elasticity	buckling test ISO 1520 depth 4,2 mm with layer 80 micrometers
Salt spray test	ASTM D1654-92240 after 1500 hr. with max. 2 mm under-creepage

Colours

Mountable parts	RAL7047 (Tele Grey 4).
Enclosure	RAL7001 (Silver Grey).
Operating panel	RAL 3005 (Wine Red) and RAL 7001 (Silver Grey).

1.7. Mechanism

The mechanism is a hand operated or hand/motor operated spring charged mechanism, connected to the vacuum interrupters and the change-over switch. It is operated via two rotating shafts on the front provided with the necessary mechanical interlocks to avoid wrong operation.

The mechanism is provided with viewing windows on the front for direct visual indication of the earthed position of the change-over switch and the ON-OFF position of the main vacuum interrupter. The front operating panel is also provided with a black & white single line mimic, showing the positions of the vacuum interrupter and the earth/busbar position of the change-over switch.

Closing

The closing spring is charged first (manually with the operation handle or by motor), automatically followed by the closing movement. During the closing movement the opening springs are charged automatically.

Opening

Opening is achieved by pressing the red mechanical trip pushbutton on the front or by energising the trip coil via the integrated overcurrent protection relay or via a remote trip signal.

The load break switch is provided with an anti-reflex mechanism. This means that opening is not possible during the closing movement and until 3s after contact touch of the switch. Closing on a fault, resulting in a short-circuit current, cannot result in an attempt of the load break switch to interrupt this short-circuit current. A load break switch is designed for interrupting load currents and not for interrupting short-circuit currents.

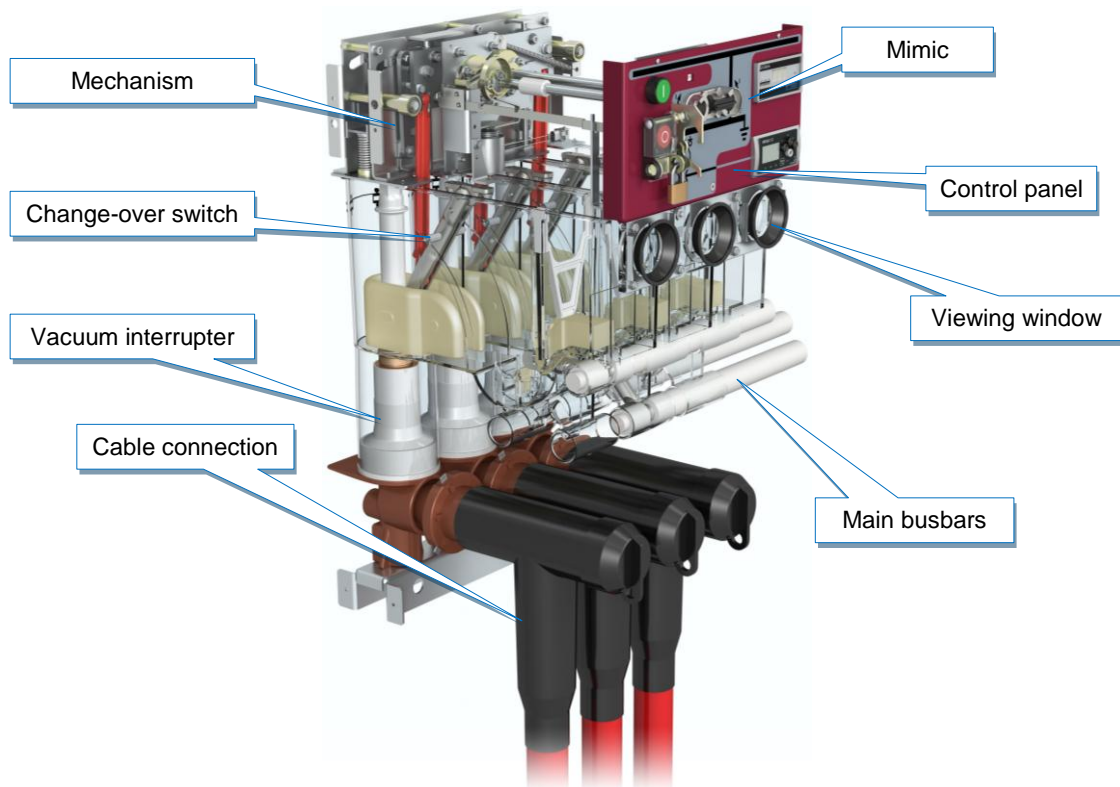

1.8. Remote control

Hand operated load break switches and circuit breakers can be provided with remote control. When selected, remote ON-OFF operation of the vacuum interrupter in service position can be achieved.

All remote control options are described in the standard wiring diagram R34S30291. They can be selected as follows:

Remote signalling

The vacuum interrupter and the change-over switch are provided with auxiliary contacts (Q1 and Q2), wired to the front terminal strip (X1).

Additional remote signalling of the optional trip indicator (H1) on the circuit breaker or the optional short circuit indicator on the load break switch (H1) can be selected separately.

Remote tripping load break switch

The load break switch panel will be provided with a 24V DC trip coil (Y2) and with the remote signalling contacts (Q1 and Q2) as described above. An electronic controller (K7) checks the position of the vacuum interrupter and the change-over switch. The selector switch (S4) must be in the middle position for correct operation of the remote trip function.

Remote tripping circuit-breaker

When the remote tripping of the circuit-breaker is selected, the existing 24V DC trip coil from the protection circuit (Y2) will be used for remote tripping. For this purpose a selector unit (K8) is mounted. The circuit-breaker panel is also provided with the remote signaling contacts (Q1 and Q2) as described above. An electronic controller (K7) checks the position of the vacuum interrupter and the change-over switch. The selector switch (S4) must be in the middle position for operation of the remote trip function.

Remote operation

A panel with remote operation is provided with the auxiliary contacts and the trip coil as described above and additionally a closing motor (M1) is mounted. To avoid inserting an operating handle during the closing operation, a blocking coil (Y1) is placed in the mechanism. The selector switch (S4) must also be in the middle position for correct operation of the remote operation.

Simple tripping circuit-breaker

A circuit breaker can also be provided with a simple remote trip function by using the existing protection trip coil (Y2) for remote tripping. For this purpose a selector/timer unit (K8) is mounted. Only 24 V DC can be applied for this function.

Auxiliary power supply

The auxiliary power supply for the remote tripping and operation is 24 V DC. When a different voltage is used, each panel can be provided with an additional voltage converter (U10).

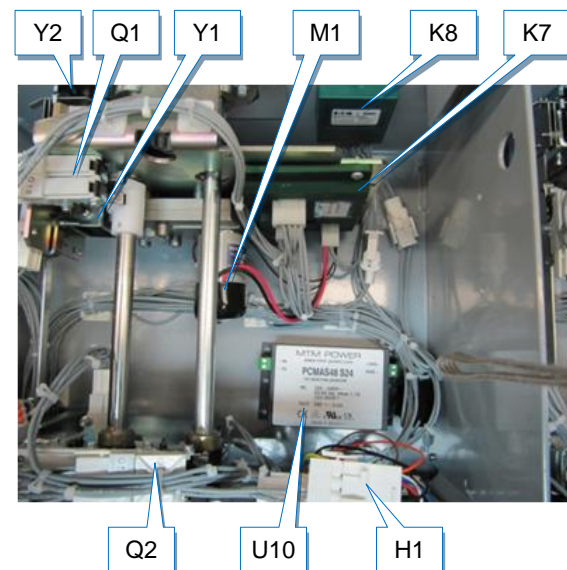

1.9. Manual operation

Manual operation of the switchgear is achieved with one operating handle, which is inserted in the access holes on the front.

Placing the handle in the left hole and turning it clockwise will close the vacuum interrupter.

Placing it in the right hole and turning it clockwise will move the change-over switch from the busbar position to the earthed position.

Turning the handle anti-clockwise it will move the change-over switch from the earthed position to the busbar position.

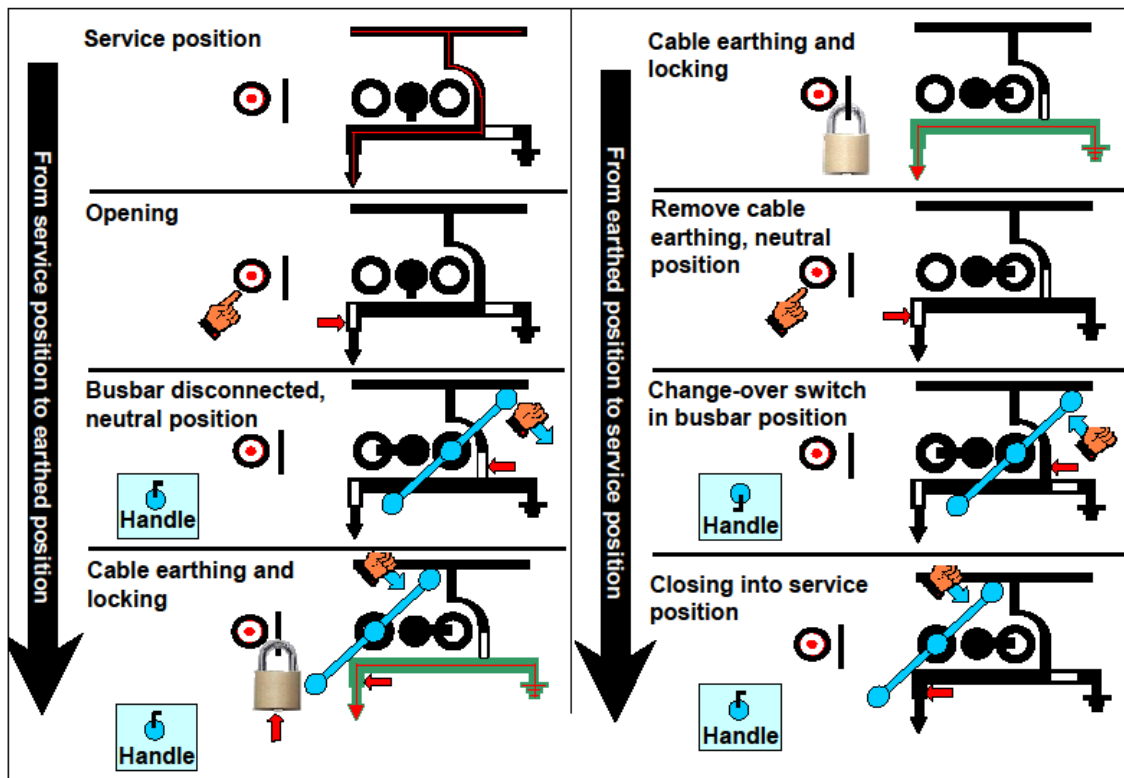

1.10. Interlocks

The Xiria unit is equipped as standard with built-in mechanical interlocks and with padlockable interlocks to prevent wrong switching operations.

Built-in interlocks

- Interlock to prevent cable access from being opened if cable is not earthed. Note: Once the cable access has been opened, the panel can be switched off to carry out cable tests; this interrupts the cable-earth link.
- Interlock to prevent operation of the change-over switch when the circuit-breaker or load-break switch is in the ON position.
- Interlock to prevent operation of the vacuum interrupter when the change-over switch is not in an end position (busbar or earth position).
- The operating handle can only be removed in an end position. (vacuum interrupter fully open or closed, change-over switch fully in busbar or earth position)

Padlockable interlocks

- The active earthed position of the circuit-breaker or load break switch can be locked with a padlock. This lock can be applied when the change-over switch is in the earthed position and the vacuum interrupter is switched ON and the cable access compartment door is closed.
- Interlock of the OFF button of the circuit-breaker or load break switch. This padlock prevents the unintentionally opening by hand of the circuit-breaker or load break switch. The flap in front of the opening button cannot be lifted while this padlock is in place. However, switching off by the protective relay, if fitted, remains possible.
- Interlock of the OFF position of the circuit-breaker or load break switch. This interlock can be applied with the change-over switch in busbar or in earthed position. Use is made of a separate accessory (padlockable locking scissor) which is placed in the access hole for the operating handle of the vacuum interrupter.

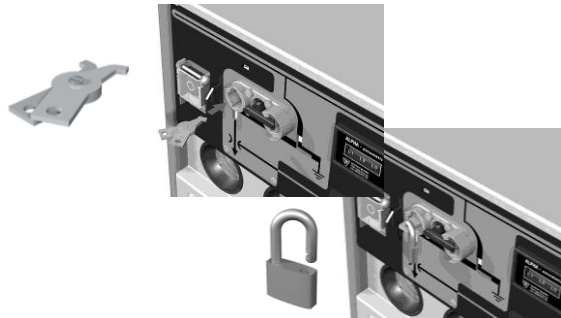

Castell lock behind a cable compartment door

Locking the panel:

1. Switch the panel in closed earthed position
2. Remove the front door of the cable compartment
3. Take the Castell key out
4. The door cannot be replaced as long as the key is not replaced.
5. The panel cannot be switched to service position.

Unlocking the panel:

1. Switch the panel in closed earthed position
Replace the key into the Castell lock
2. Place the front door
3. The panel can now be switched into the service position.

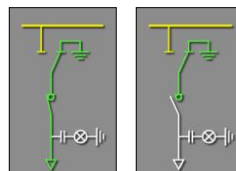

General description

Application Guide Xiria

1

1.11. Position indication

The front black and white mimic shows all positions of the circuit-breaker and the load break switch during operation.

The ON-OFF position of the vacuum interrupter and the earth position of the change-over switch are also visible through the inspection windows on the front.

	Service position	Open position	Isolated position	Earthed position
Front panel				
Diagram				
Switching position				
Inspection window				

1.12. Switchgear compartment

Two basic panel versions are available:

- a vacuum load break switch for ring cable connections;
- a vacuum circuit-breaker for the protection of main transformers and cable connections. Both versions can be supplied in any combination and sequence in a unit.

Busbars

The busbars are made of tube shaped copper parts, mounted in the unit with a steel rod inside to provide the necessary contact force.

These busbars are fully insulated and cannot be extended.

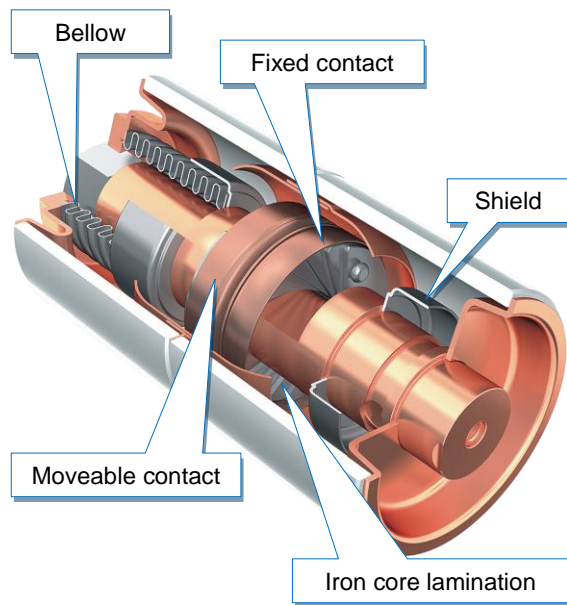

Vacuum interrupters

The Xiria switchgear is provided with Axial Magnetic Field (AMF) interrupters because of the negligible contact erosion and the excellent switching performance at low and high fault currents. The benefit of negligible contact erosion makes this type of interrupter particularly suitable for use in non-withdrawable switchgear systems and sealed systems, because replacement of the interrupter during the technical life of the unit has become unnecessary. This also allows for the manufacturing of maintenance free switchgear.

With the horse-shoe shaped iron core laminations inside the main contacts the magnetic field, generated during a short-circuit current, is forced in axial direction between the contacts during the interruption of this short-circuit current.

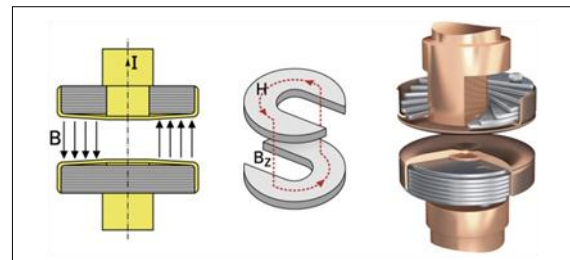

Axial magnetic field

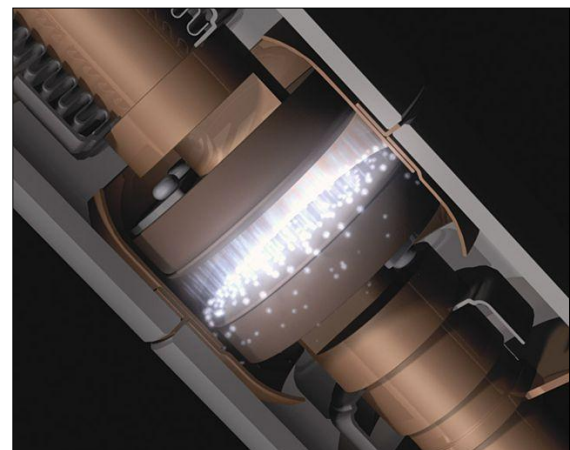

Short-circuit interruption with the diffuse discharge principle

1.13. Cable compartments

Plastic insulated cables can be connected to Xiria switchgear, for which standard cable connectors can be applied. To ensure that the cables are correctly supported, the panels are provided with short-circuit resistant synthetic cable clamps.



When more space for the cable connection is needed, the switchboard can be provided with an optional plinth.

Both plug and screw type cable connectors can be supplied up to and including 24 kV. For this purpose, the panels are provided with standard cones. The connectors are not supplied together with the Xiria system. There are various types available on the market that can be obtained with or without the associated test equipment. For application above 12 kV, only connectors with a safe earthed layer on the outside should be applied, because of the very limited space available and prevention of discharging. In addition, the earth bar, the current transformers for the protection relay and, when required, for ammetering are located in the cable compartment. The cable compartment door is provided with a mechanical interlock to prevent opening when the panel is not in the closed earthed position. On request internal arc resistant cable doors can be mounted. Also deeper doors are available to mount cable plugs which need more space inside the compartment.

Earth bar

Inside the cable compartment a copper earth bar is mounted. This bar is provided with three nuts M10 in each cable compartment for the connection of the earthed screens of the primary cables.

In the most left and the most right cable compartment an extra nut M10 is placed for an additional internal earth connection.

The earth bar can also be connected to the station earthing system on both sides of the switchgear, using a M12 bolt connection. For this purpose the bar protrudes 50 mm from the enclosure on both sides.

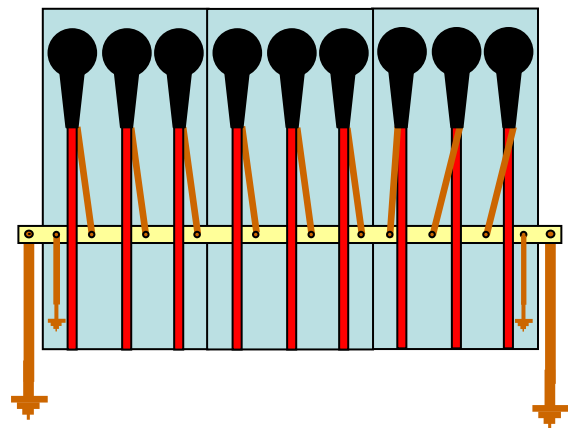

1.14. Operating conditions

Temperature

The standard service conditions for indoor type switchgear are described in IEC 62271-1. The Xiria system complies with this specification in the class "minus 25 indoor". Ambient temperatures may vary between -25 and +40 °C., however higher maximum temperatures are allowed when the maximum load current is derated as follows:

Ambient	24h avg.	LBS (A)	CB (A)
40°C	35°C	630	200 or 500
45°C	40°C	605	200 or 500
50°C	45°C	577	200 or 500
55°C	50°C	555	200 or 500

Degree of protection

The standard degrees of protection for indoor type switchgear are described in IEC 62271-1. The primary enclosure with the vacuum interrupters, the mechanisms and the change-over switches is ambient proof with conditioned dry air inside. This enclosure is sealed for life (> 25 yr) against the penetration of moist and dust. The outside enclosure, the cable compartments and the operating front have a protection degree of IP31D under normal service conditions. When the top or front covers are opened the protection degree is IP2X.

Height

The switchgear is designed for operation under "normal service conditions" in accordance with IEC 62271-1. This means that the switchgear should not be installed in areas higher than 1000 metres. For application in areas above this height, the test voltage has to be increased as laid down in IEC 60072-2. The multiplication factor (Ka) is as follows:

Height (m)	Ka
1000	1
2000	1.13
3000	1.28

For in-between values, the Ka factor can be determined by using the following formula:

$$Ka = e^{(H-1000)/8150}$$

In practice, this factor means that, for example, 24 kV systems that have been installed in higher areas, can only be used as 17.5 kV systems. A specific solution can be chosen in consultation with the customer case by case.

2. Green design

Xiria and the other medium voltage switchgear systems carrying Eaton's Holec brand are based on the use of vacuum switches combined with solid insulation material. This is an environmentally-friendly technology in comparison with the methods used by many other suppliers, which use SF₆ as an insulation gas.

2.1. Supporting Green Switching initiative

Due to a growing concern about the impact of global warming, several utilities and Eaton are joined in the Green Switching initiative. Green Switching is a platform of users, manufacturers, Non Governmental Organisations and other participants who are concerned about the growing use of SF₆ for MV applications. The participants share the idea that the use of SF₆ should be prevented wherever there are alternatives available on the market. The Green Switching platform has published a position paper and several related publications. It also presents scientific and technical articles about SF₆ and its alternatives on a website.



More information: www.greenswitching.com

As a result of this Green Switching initiative there is a growing consciousness in the energy distribution market about the use of SF₆. Utility network companies, industrial users, owners of railway and underground infrastructure and public private investors in the healthcare sector are becoming more aware of the health & safety aspects of SF₆ and its toxic by-products as well as its impact on global warming. This has resulted in a growing concern about the use of SF₆ for MV applications.

Xiria is made exclusively of environmentally-friendly materials. The insulation medium is clean, dry air and the switching medium is vacuum. Thus Xiria responds to the demand for sustainability in energy distribution. The unit is easy to dismantle at the end of its service life as the materials used are clearly labelled and can be reused. This facilitates recycling and avoids excessive costs and environmental taxes when the unit is decommissioned.

2.2. Environmental declaration

Supplier	Eaton Industries (Netherlands) B.V.
Address	Europalaan 202 7559 SC Hengelo The Netherlands

1. In the medium voltage switchgear type Xiria there are no poisonous or otherwise hazardous materials nor materials which may or can affect the ozone layer or influence the greenhouse effect.
2. The Xiria switchgear contains materials which can be recycled. The epoxy resin can be broken up at the end of its life-cycle. The copper, aluminium and other metal parts can be recycled.
3. At the end of its life cycle the Xiria switchgear can be traded in at Eaton.
4. List of materials used for manufacturing a typical Xiria 3-panel switchgear unit:

Metals	[kg]
Steel	335.0
Zinc coated steel	11.0
Aluminium	0.5
Copper	30.0
Ceramic	3.0
Silver	0.5
Epoxy	19.0
Total weight metals	399.0

Plastics	[kg]
PE	16.0
EPDM	0.5
PP	1.0
PC	5.0
TPU	0.5
Total weight plastics	23.0

Total weight	[kg]
Metals	399.0
Plastics	23.0
Total weight Xiria	422.0

3. Product range

The Xiria product range consists of vacuum load break switches for ring cable connections and vacuum circuit-breakers for protecting transformers and cable connections.

3.1. Load break switch

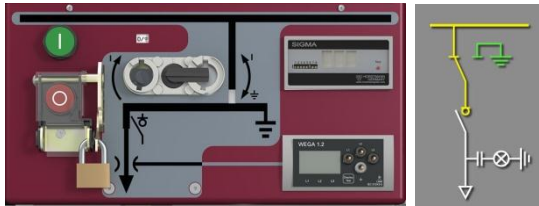

Standard specification of an IEC 630 A Load Break switch panel (LBS):

- Manual spring-operated vacuum load-break switch
- Change over switch (earthed/service position)
- Voltage detection set (WEGA 1.2)
- Manual spring charging and closing mechanism with mechanical OFF-button
- Cable compartment non arc resistant, provided with:
 - Cable door
 - 630 A cones type C for bolted type T-connectors (connectors not included)
 - Cable fixing clamps and earth bar

Available standard options

- Short circuit indicator type SIGMA
- Remote signalling, 24 V DC trip coil and 24V DC closing motor
- Voltage converter for remote control

Short circuit indicator type SIGMA

Each Xiria load break switch panel can be provided with a short circuit indicator, connected via internal wiring to three current transformers mounted around the cable connection cones. It shows the presence of a through-going short circuit current in each of the phases.



If the phase current exceeds either the preset trip current for the duration of the programmed response time or the previously flowing operating current by a defined factor (self-adjustment), the fault-affected phase will be indicated by a brightly flashing LED, consequently activating the remote indication contact.

If a second tripping occurs within the reset time, for example when automatic re-closing is in process, a signal will be given by a double flashing LED. The device is arranged to be reset automatically in accordance with a pre-fixed time, by closing of an externally connected relay contact, or manually via push-button. Moreover, a function test can be carried out either by means of this button or by an external relay contact. The current transformer type is provided with factory setting. The trip current, the response time, the reset time, and the kind of remote indication contact (permanent or momentary contact) can be selected via front switches.

Electrical details

Trip current (I_k)	100 A, 200 A, 300 A, 400 A, 600 A, 800 A, 1000 A either fixed setting or self-adjusting.
Self-adjustment	in relation to the operating current (I _b): I _b < 100 A: I _k = 400 A, I _b > 100 A: I _k = 4 x I _b , I _k max = 1000 A
Response time	40 ms or 80 ms delay time
Time reset	1, 2, 4 or 8 h
Remote	reset and remote setting via external momentary contact
Temperature range	-30 °C to +70 °C
Power supply	Longlife lithium cell battery, shelf life ≥ 20 year, 1000 flash hours
Relay contact	Permanent of momentary contact (1s) 230 V AC / 1,0 A / 62,5 VA 220 V DC / 1,0 A / 30 W max
Rated voltage	3 kV...36 kV (rated voltage of the switchgear)

For more details of the short circuit indicator see the technical SIGMA data sheets.

3.2. Circuit breaker

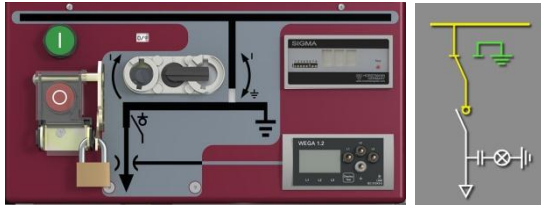

Standard specification of an IEC 200 A Circuit Breaker panel (CB):

- Manual spring-operated vacuum circuit-breaker
- Integrated protection relay make SEG type WIC1-1PE (over current and earth fault protection)
- Trip coil
- Change over switch (earthed/service position)
- Voltage detection set (WEGA 1.2)
- Manual spring charging and closing mechanism with mechanical OFF-button
- Cable compartment non arc resistant, provided with:
 - Cable door
 - Three current transformers for protection
 - 200 A cones type A for plug type Elbow connectors (connectors not included)
 - Cable fixing clamps and earth bar

Available standard options

- 500 A nominal current instead of 200 A
- Trip indicator type SZ4H or SZ5H
- Remote signalling contacts, 24 V DC trip coil and 24 V DC closing motor
- Voltage converter for remote control
- DIP or HEX setting switches on the front of the protection relay
- WIC1 or WIB1 protection relay
- TLF protection unit (Time Limit Fuse protection)
- Cable cones type C instead of type A for bolted cable connections
- Ammeter in L2 phase with current transformer in cable compartment

Protection relays and current transformers

The protection relay is a self powered relay make Woodward SEG, energised from the current transformers. These transformers are placed around the cable cones inside the cable compartment.

The relay generates a pulse for the trip coil in the mechanism to open the circuit-breaker when a fault current is detected.

The following relay versions are available:

- WIC1 1PE over current and earth fault
- WIC1 2PE over current and earth fault with DIP switches on the front
- WIC1 3PE over current and earth fault with HEX switches on the front
- WIB1 2PE over current and earth fault with DIP switches on the front
- WIB1 2FE over current and earth fault with DIP switches on the front

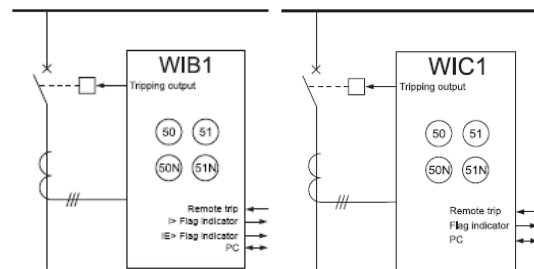

For details concerning the settings of over currents, short circuit currents, earth fault currents and timing see the relevant Woodward relay manuals.

Trip indicator

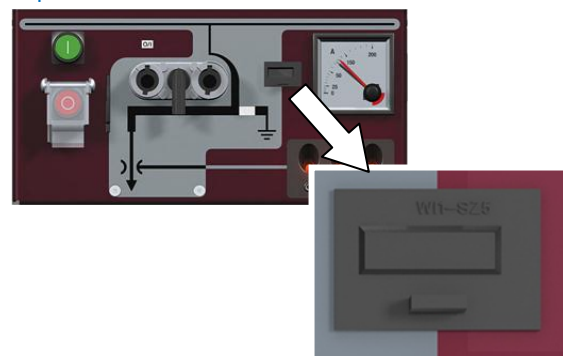

The protection relay can be fitted with a trip indicator, mounted on the front of the Xiria, type SZ4H (without aux. contact) or type SZ5H (including aux. contact). This trip indicator is manually reset after trip on the front of the indicator.

TLF protection unit (Time Limit Fuse protection)

ENA technical specification 12-6 issue 1:1973

Time fuse links (for use with current transformer releases on circuit breakers).

Time Limit Fuse protection is an evolution from the famous Cleveland protection principle. In this design the single phase short circuit currents and earth faults are detected by the low voltage fuses in the circuit, resulting in a trip command to the circuit-breaker through a patented electronic circuit. It is an alternative for the standard electronic protection relay type WIC1.

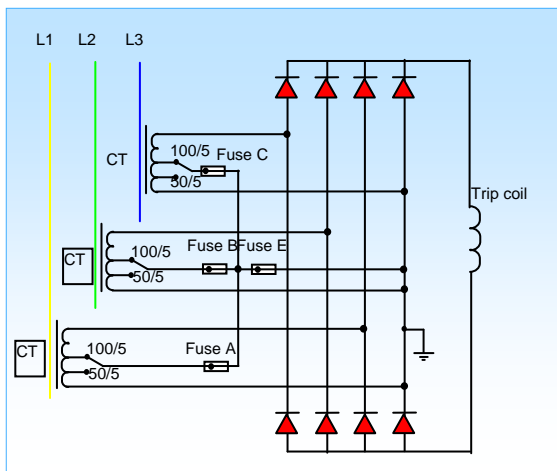

Fuse A,B,C = short circuit protection

Fuse E = earth fault protection

When a function is not needed, the fuse can be replaced by a link.

kV	kVA	CT Ratio	TLF Fuse Rating (A)
6.6	200	50/5	5.0
6.6	300	50/5	10
6.6	315	50/5	10
6.6	500	100/5	7.5
6.6	750	100/5	12.5
6.6	800	100/5	12.5
6.6	1000	100/5	15
11	200	50/5	3.0
11	300	50/5	5.0
11	315	50/5	5.0
11	500	50/5	10
11	750	100/5	7.5
11	800	100/5	7.5
11	1000	100/5	10



Ammeter in L2 phase including current transformer

A circuit-breaker can be provided with an optional ammeter on the front, connected to a current transformer inside the cable compartment.

Ammetering is possible in phase L2, only when single phase cables are connected.

Ammeter

Type	make ELEQ, bimetal instrument type BIV72, delay 8 min.
Dimensions	72 x 72 mm.
Scale	15 A, 25 A, 40 A, 60 A, 100 A, 200 A, 500 A

Current transformer

Type	make ELEQ, RM120-E6A
Dimensions	120 x 145 x 64 mm. (wxdxh)
Cable diameter	max. 50 mm.
Class	cl.3
Wiring	Halogene free 2.5 mm ²
Temperature range	- 40 ... + 85 °C
I_{th}	20 kA-1s



Current transformer and ammeter

4. Voltage detection

4.1. Detection system

Each Xiria panel is provided with a voltage detector, mounted on the front.

It is connected via internal wiring to capacitive sensors inside the cable connection cones. It shows the presence of the primary voltage on all three phases of the primary cable connected to the panel.

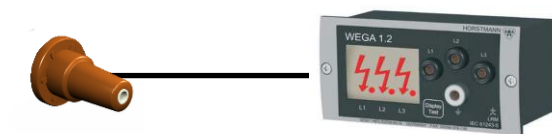

This integrated voltage detecting system (make Horstmann type WEGA 1.2) is used for continuous operation. The condition “voltage present” is displayed by arrows and respectively arrows and dots.

4.2. Electric details

Rated voltage	3 kV ... 36 kV (rated voltage of the switch gear)
Rated frequency	50 Hz
Operating temperature	-25°C...+55°C (according to the operating temperature of switchgear)
Power supply	generated by the voltage to be tested
Interface	LRM-System for every phase
Indication	
Arrow	Means „Voltage present“. The display appears in the range of 0,1...0,45 U _n .
Dot	Means that the current flowing through the detecting system fulfills the requirements for integrated voltage detecting systems (VDS) of VDE 0682 part 415. This constant monitoring makes a maintenance test not necessary.
No indication	All the symbols are turned off in the switchgear condition with all-poles switched off/ disconnected.

4.3. Testing

The display of the detector can be tested by using the piezo-button on the front of the unit. The full functionality can be tested by using the functional tester, available as an option.

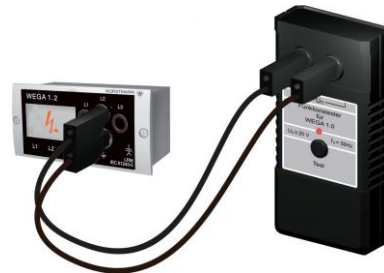

Phase comparison is possible by using an external phase comparator in accordance to VDE 0682 part 415, for example the ORION 3.0 (make Horstmann) which has to be plugged in the earth and test point (LRM system). These test points are accessible after removing the protective cap.

For more details of the voltage detector and the optional test equipment see the technical data sheets WEGA 1.2, Orion 3.0 and Orion Compare.



5. Technical data

5.1. General

Rated voltage	kV	3.6	7.2	12	17.5	24
Impulse withstand voltage	kV	40	60	75 95	95	125
Power frequency withstand voltage	kV-1m	10	20	28/38/42	38	50
Rated frequency	Hz	50/60	50/60	50/60	50/60	50/60
Degree of protection in service		IP31D	IP31D	IP31D	IP31D	IP31D
Degree of protection with doors/covers open		IP2X	IP2X	IP2X	IP2X	IP2X

5.2. Classification according to IEC 62271-200

Loss of service continuity	LSC2B	LSC2B	LSC2B	LSC2B	LSC2B	LSC2B
Partition class	PM	PM	PM	PM	PM	PM
Internal Arc Classification (IAC)	AFL	AFL	AFL	AFL	AFL	AFL
Internal arc resistance	kA-s	20-1	20-1	20-1	16-1	16-1
Internal arc resistance with absorber	kA-s	16-1	16-1	16-1	16-1	16-1
Internal arc resistance cable compartment	kA-s	16-1	16-1	16-1	16-1	16-1
Internal arc resistance cable comp. alternative	kA-s	20-1	20-1	20-1	16-1	16-1
Ambient air temperature range	°C	-25 +40	-25 +40	-25 +40	-25 +40	-25 +40
Maximum altitude	m	1000	1000	1000	1000	1000
Average Watt losses per panel	W	100	100	100	100	100
Sound emission	dB(A)	<70	<70	<70	<70	<70

5.3. Busbar system

Rated normal current	A	630	630	630	630	630
Rated short-time withstand current	kA-s	20-1	20-1	20-1	16-1	16-1
Rated short time withstand current alternative	kA-s	20-3	20-3	20-3	16-3	16-3
Rated peak withstand current	kA	50	50	50	40	40

5.4. Circuit-breakers

Rated normal current	A	200/500	200/500	200/500	200/500	200/500
Rated breaking current	kA	20	20	20	16	16
Rated short-circuit making current	kA	50	50	50	40	40
Rated Capacitive Switching Current Class		C2	C2	C2	C2	C2
Rated Cable Charging Breaking Current	A	31.5	31.5	31.5	31.5	31.5
DC Time Constant	msec	45	45	45	45	45
DC Component	%	<20	<20	<20	<20	<20
Mechanical Endurance Class		M1	M1	M1	M1	M1
Mechanical Endurance Class as Earth Switch		M1	M1	M1	M1	M1
Mechanical Endurance Class Disconnecter		M0	M0	M0	M0	M0
Electrical Endurance Class		E2	E2	E2	E2	E2
Rated short-time withstand current	kA	20-1	20-1	20-1	16-1	16-1
Rated short-time withstand current alternative	kA	20-3	20-3	20-3	16-3	16-3
Minimum tripping time	msec	80	80	80	80	80
Mechanism type		O - 3 min - CO - 3 min - CO				

5.5. Load break switches

Rated normal current	A	630	630	630	630	630
Rated active load break current	A	630	630	630	630	630
Rated short-circuit making current	kA	50	50	50	40	40
Rated short-time withstand current	kA-s	20-1	20-1	20-1	16-1	16-1
Rated short-time withstand current alternative	kA-s	20-3	20-3	20-3	16-3	16-3
Rated Cable Charging Breaking Current	A	31.5	31.5	31.5	31.5	31.5
Mechanical Endurance Class		M2 5000x	M2 5000x	M2 5000x	M2 5000x	M2 5000x
Mechanical Endurance Class as Earth Switch		M0	M0	M0	M0	M0
Mechanical Endurance Class Disconnecter		M0	M0	M0	M0	M0
Electrical Endurance Class		E3	E3	E3	E3	E3
Electrical Endurance Class as Earth Switch		E2	E2	E2	E2	E2

5.6. Remote control options

Wiring diagram	R34S30291
Standard auxiliary voltage	24 V DC
Auxiliary voltage with voltage converter	36 - 72 V DC & 36 - 60 V AC 100 - 353 V DC & 100 - 240 V AC
Auxiliary voltage tolerances	+10% -30%
Watt losses controller K7	5 W continuous when idle
Power supply for closing motor	55 W 15 sec
Power supply for trip coil	40 W 100 msec

5.7. Changing the voltage

When a switchboard is originally ordered for a lower voltage than 24 kV and it will be used for 24 kV in future, it must be manufactured, tested and delivered according to the 24 kV design.

A switchboard can only be used for 24 kV when "24 kV" is mentioned on the rating plates.

24 kV-switchboards can be used for 12 kV without restrictions, only the maximum short circuit capacity will be limited to 16 kA instead of 20 kA.

6. Standards

Xiria complies with the following international standards

IEC62271-1	Common specifications for high-voltage switchgear and control gear standards
IEC62271-100	High-voltage alternating-current circuit-breakers
IEC62271-102	Alternating current disconnectors and earthing switches
IEC62271-103	High-voltage switches
IEC62271-200	A.C. metal-enclosed switchgear and control gear for rated voltages above 1 kV and up to and including 52 kV
IEC62271-304	Additional requirements for enclosed switchgear and control gear from 1 kV to 72.5 kV to be used in severe climatic conditions
IEC60529	Degrees of protection provided by enclosures
IEC60044-1	Instrument transformers - Part 1: Current transformers
IEC60044-2	Instrument transformers - Part 2: Inductive voltage transformers
EN50181	Plug-in type bushings above 1 kV up to 36 kV
ISO 9001-2000	Quality
ISO 14001	Environmental management



7. Tariff metering

Xiria switchgear can be provided with tariff metering class 0.2. This tariff metering is available in two versions: the 24 kV Xiria M and the 12 kV Xiria MA.

7.1. Xiria M (max. 24 kV)

Xiria M consists of a three or four panel unit where the most right panel (a circuit breaker) is provided with two primary plug connections per phase.

One connection with internal primary cables is used for a set of three voltage transformers, mounted in the plinth of the unit. The second set is used for the primary cables for the power transformer connection.

The current transformers for tariff metering and the current transformers for protection are both placed in the cable compartment around the this primary cable.

The following current- and voltage transformers are available:

3 current transformers for tariff-metering at choice

- 200/5 A 5 VA class 0.2S FS5
- 150/5 A 5 VA class 0.2S FS5
- 100/5 A 5 VA class 0.2S FS5
- 75/5 A 5 VA class 0.2 and 0.5S FS5
- 50/5 A 5 VA class 0.5S FS5
- 120-60/5A 5 VA class 0.5S FS5 for 60/5A
5 VA class 0.2S FS5 for 120/5A
- 100-50/5A 5 VA class 0.5S FS5 for 50/5A
5 VA class 0.2S FS5 for 100/5A



3 cable side connected voltage transformers

Single-phase cast resin insulated voltage transformers

xxxxx/√3 // xxx/√3 // 100/3 V at choice:

- 10000/√3 // 100/√3 // 100/3 V
- 10000/√3 // 110/√3 // 100/3 V
- 11000/√3 // 100/√3 // 100/3 V
- 11000/√3 // 110/√3 // 100/3 V
- 13750/√3 // 110/√3 // 100/3 V
- 20000/√3 // 100/√3 // 100/3 V
- 20000/√3 // 110/√3 // 100/3 V
- 22000/√3 // 100/√3 // 100/3 V
- 22000/√3 // 110/√3 // 100/3 V
- 24200/√3 // 110/√3 // 100/3 V
secondary winding 10 VA class 0.2
tertiary winding 30 VA class 3P

The primary and secondary windings of the transformers are star connected. Both neutral points are earthed.

The tertiary winding is connected as open delta and is provided with a choke coil and resistance to prevent ferro resonance.

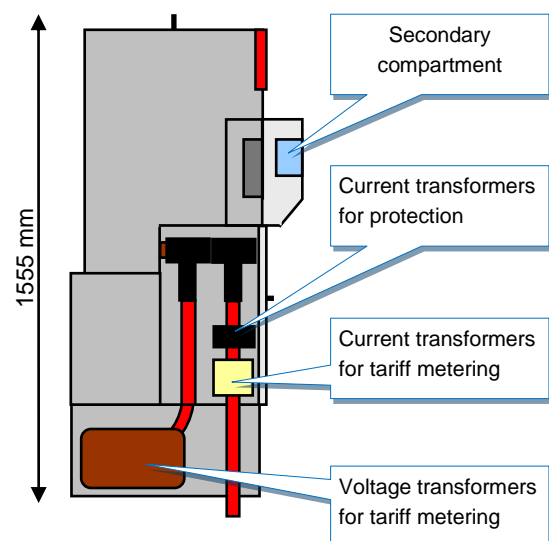

7.2. Xiria MA (max. 12 kV)

Xiria MA consists of a three or four panel unit where the most right panel (a circuit breaker) is provided with two primary plug connections per phase.

One connection with internal primary cables is used for a set of three voltage transformers, mounted in the back of the unit. The second set is used for the primary cables for the power transformer connection.

The current transformers for tariff metering and the current transformers for protection are both placed in the cable compartment around the this primary cable.

The following current- and voltage transformers are available:

3 current transformers for tariff-metering at choice

- 200/5 A 5 VA class 0.2S FS5
- 150/5 A 5 VA class 0.2S FS5
- 100/5 A 5 VA class 0.2S FS5
- 75/5 A 5 VA class 0.2 and 0.5S FS5
- 50/5 A 5 VA class 0.5S FS5
- 120-60/5A 5 VA class 0.5S FS5 for 60/5A
5 VA class 0.2S FS5 for 120/5A
- 100-50/5A 5 VA class 0.5S FS5 for 50/5A
5 VA class 0.2S FS5 for 100/5A

3 cable side connected single-phase cast resin insulated voltage transformers

xxxxx/ $\sqrt{3}$ // xxx/3 // 100/3 V at choice:

- 10000/ $\sqrt{3}$ // 100/ $\sqrt{3}$ // 100/3 V
- 11000/ $\sqrt{3}$ // 110/ $\sqrt{3}$ // 100/3 V
secondary winding 10 VA class 0.2
tertiary winding 30 VA class 3P

The primary and secondary windings of the transformers are star connected. Both neutral points are earthed.

The tertiary winding is connected as open delta and is provided with a choke coil and resistance to prevent ferro resonance.

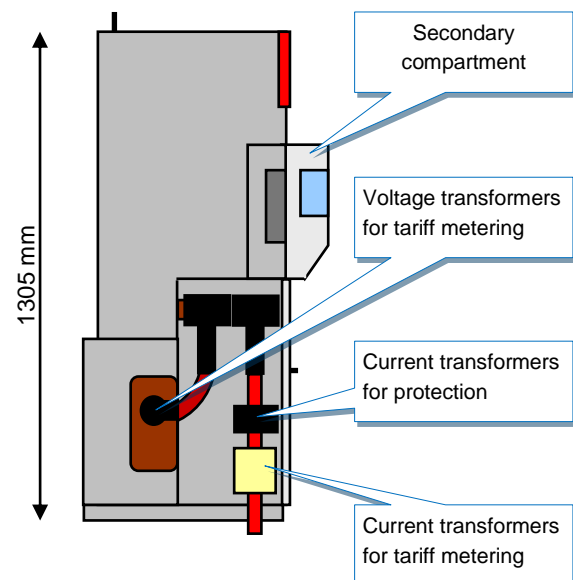

7.3. Secondary compartment

In this compartment the secondary DIN00 fuses 6 or 10 A and the terminals for the metering equipment from the customer are mounted.

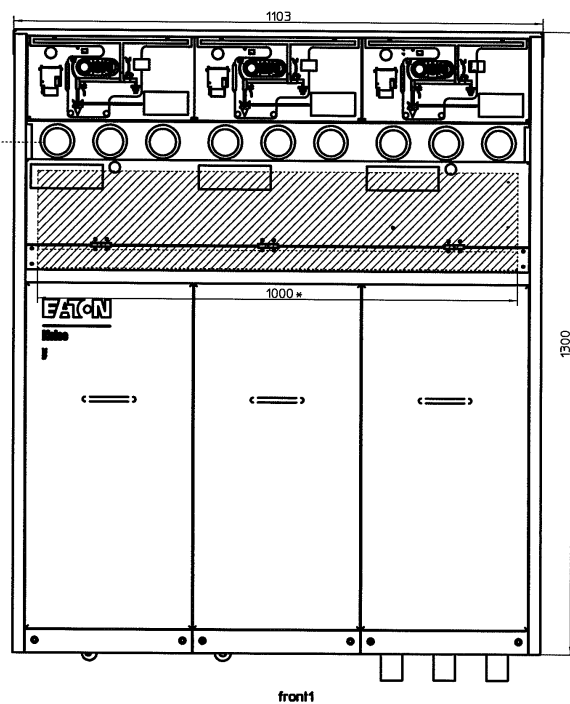
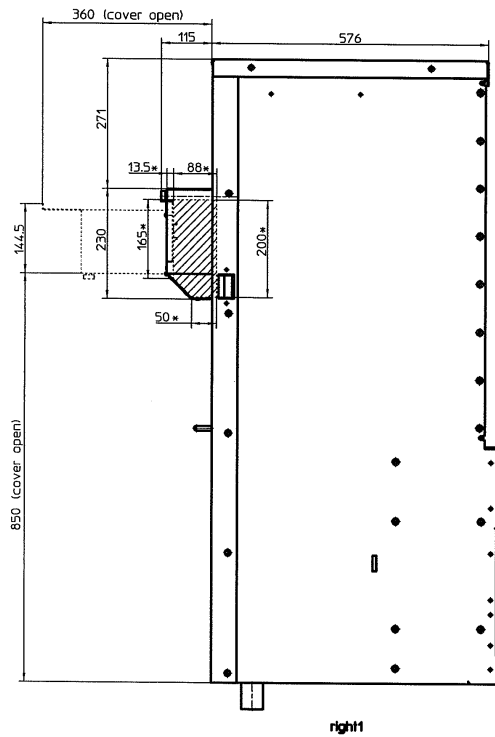

8. Shipping data

8.1. Transport and handling

Information



On the outside of the packing material the logos are shown for handling with care (fragile equipment), dry storage (no storage in wet environments) and

the centre of weight. Also the order information is placed on the outside of the packing.

For international shipping by truck / container freight



The packing consists of a wooden pallet with a cardboard box with filling material inside for protection during transport.

For domestic shipping



The packing consists of plastic wrapping around the unit and a wooden pallet.

For air freight and sea freight



The units will be packed inside a wooden crate with filling material inside for protection during transport.

Lifting

Lifting of a 2-panel unit can be done with a single lifting eyebolt on top of the unit. The 3-, 4- and 5-panel units have a steel lifting profile with two holes on top of the unit. The lifting eyebolt or profiles must not be removed because they are part of the fixation of the top cover.



8.2. Dimensions and weights

Dimensions (mm)

	Width	Height	incl. plinth Height	Depth
2 panels	760	1305	1555	600
3 panels	1110	1305	1555	600
4 panels	1460	1305	1555	600
5 panels	1810	1305	1555	600

Dimensions including packing (mm)

	Width	Height	incl. plinth Height	Depth
2 panels	1200	1600	1850	800
3 panels	1200	1600	1850	770
4 panels	1555	1600	1850	770
5 panels	1860	1600	1850	800

Weight (kg)

	Nett	Gross
2 panels	350	380
2 panels with plinth	410	440
3 panels	430	460
3 panels with plinth	520	550
4 panels	550	590
4 panels with plinth	670	710
5 panels	660	710
5 panels with plinth	810	860

9. Installation

9.1. Floor plans

Floor plan 2-panel version Xiria

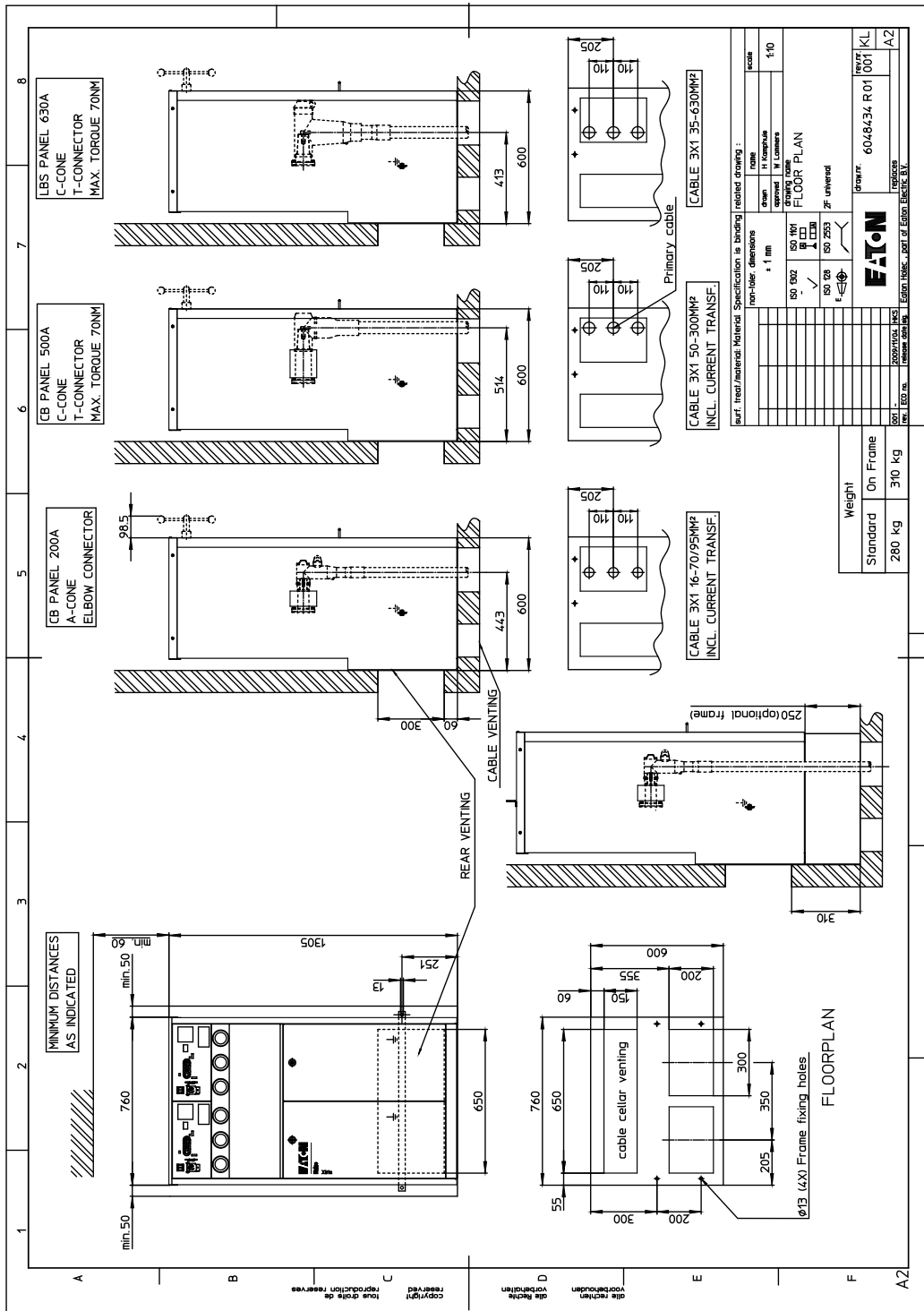

Floor plan 5-panel version Xiria

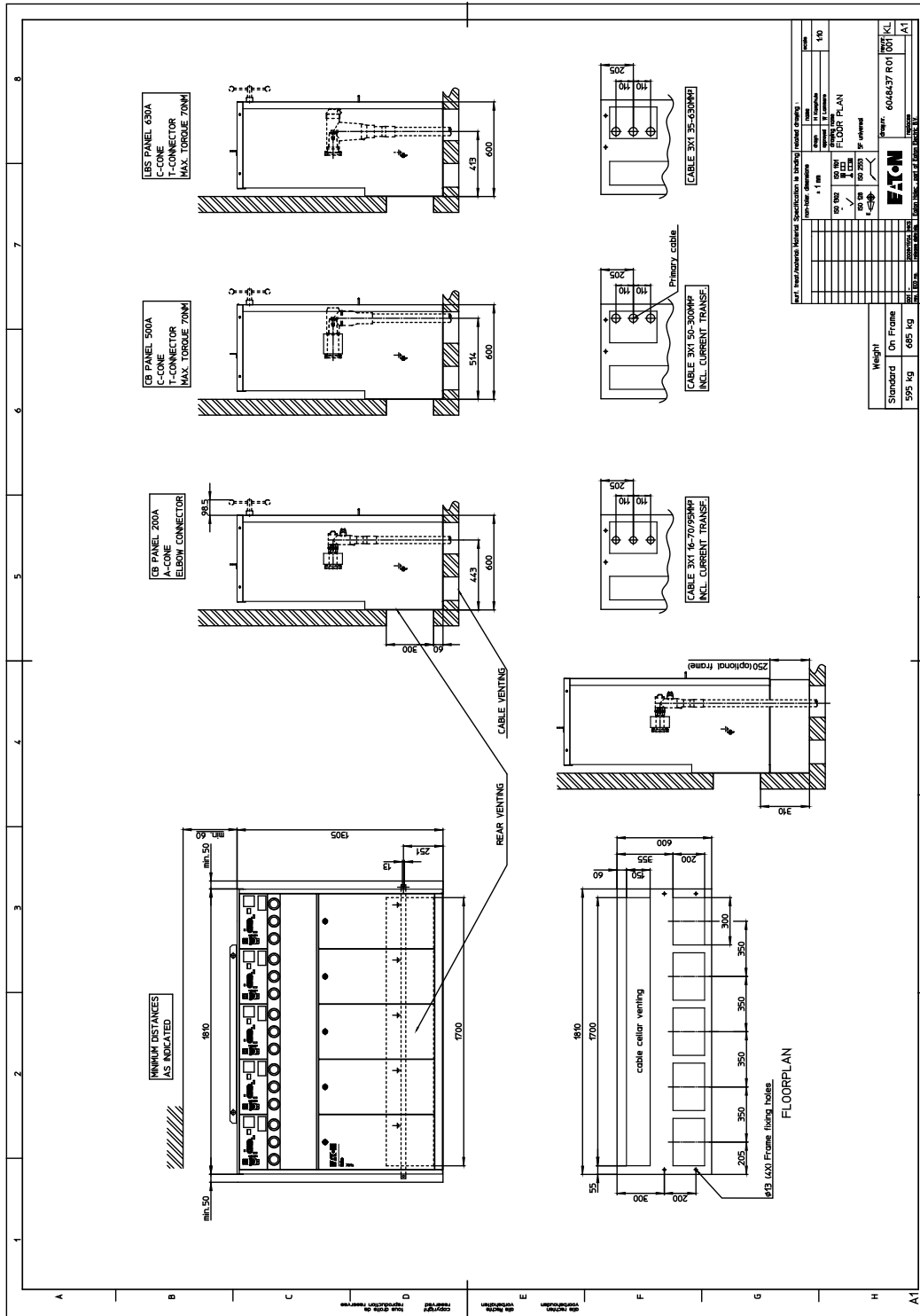

9.2. Switch room setup

The system can be placed in accessible (walk-in type) switch rooms and compact transformer stations. The Xiria switchgear is designed in accordance with the recommendations laid down in IEC622771-200. In this standard is stated that switchgear, satisfying these requirements, is designed in principle to prevent the occurrence of internal faults. To comply with this requirement the Xiria system is single pole insulated with high quality insulation materials, surrounded by a sealed enclosure which is not influenced by dust and moist.

Also the special internal electrical design keeps the electrical field levels low, resulting in the a negligible chance of internal faults to occur. Practical experience has been obtained in the market with products based upon this philosophy of single pole insulation during a period of more than 40 years. These experiences prove in a sufficient way that the possibility of an unsafe situation is negligible small.

In the international market it is common approach that, although the probability on internal arcs may be extremely low, in general they cannot be completely disregarded. In IEC 62271-200 specific attention is paid to the safety of operating personnel when an internal arc occurs in a switchboard. When installed in the correct way the Xiria switchgear also complies with this additional requirement. The Xiria system has been designed in accordance with these general recommendations set out in IEC which prevents internal faults from occurring. When set up correctly, a Xiria unit will comply with this IEC standard for setting up with an arc channel. For this purpose the Xiria switchgear is provided with pressure relief flaps and outlets at the rear and at the bottom of the unit. These outlets can be connected to the arc channel of the building when applicable. When the rear pressure relief is not used and the switchgear is not mounted against a wall the optional rear cover plate must be mounted. As an option also arc proof cable compartments are available. When an arc channel is not available in the building, the Xiria switchgear can be provided with a pressure absorber chimney mounted at the back of the unit.

See next page for different switch room setups.

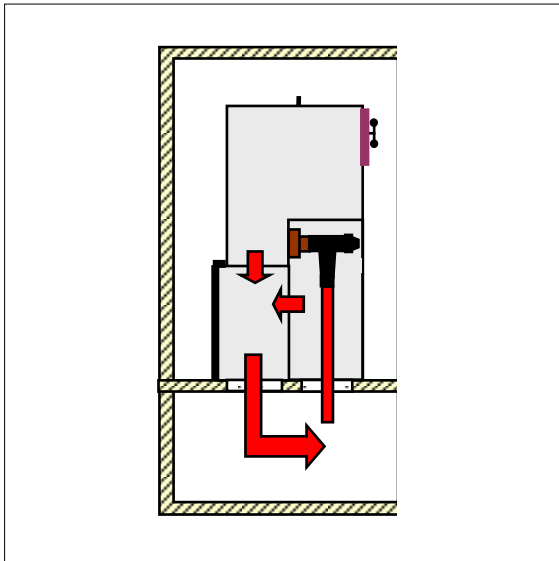

- No rear arc channel available
- Rear side provided with cover plate
- Arc channel available via cable cellar
- Max. 12 kV 20 kA-1s or 24 kV 16 kA-1s

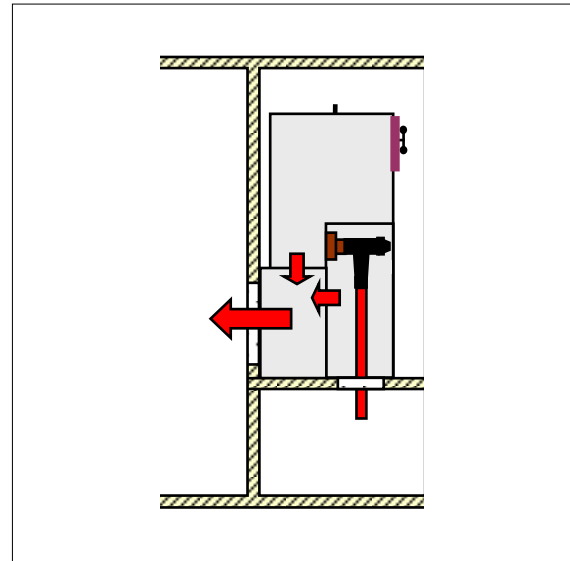

- No arc channel via cable cellar available
- Rear arc channel available to adjacent room
- Max. 12 kV 20 kA-1s or 24 kV 16 kA-1s

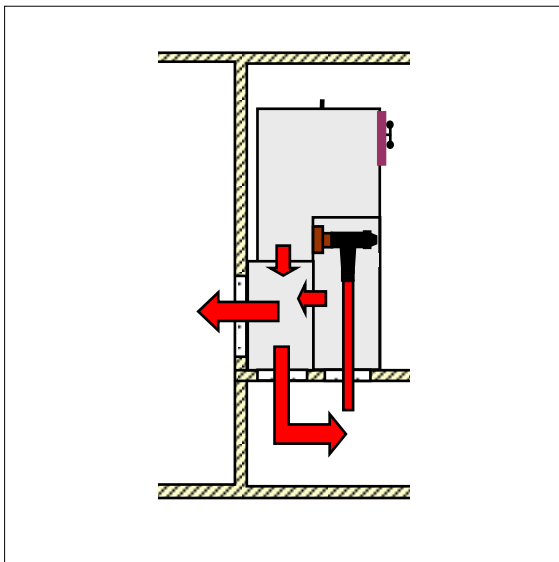

- Rear arc channel available to adjacent room
- Arc channel via cable cellar
- Max. 12 kV 20 kA-1s or 24 kV 16 kA-1s

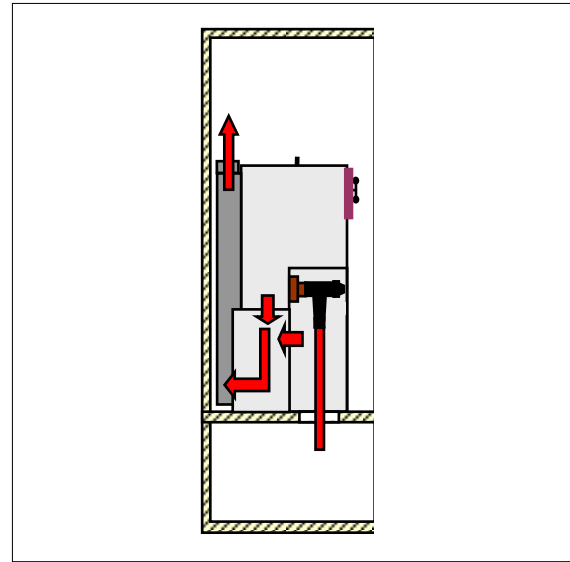

- No arc channel via cable cellar or adjacent room available
- Arc exhaust via chimney
- Max. 12 kV 16 kA-1s or 24 kV 16 kA-1s

9.3. Cable connections

Cable cones

The switchgear is provided with epoxy resin cable cones according to EN 50181.

Panel type	Cone	I [A]	Maximum short-circuit current	Connector	Cable
Load-break switch	C	630	17.5-24 kV 16 kA-1 & 3 s 3.6-12 kV 20 kA-1 & 3 s	bolted T-plug	Cu/Al XLPE Cu/Al XLPE
Circuit-breaker	A	200	17.5-24 kV 16 kA-0.6s 3.6-12 kV 20 kA-0.4s	elbow type plug	Cu/Al XLPE Cu/Al XLPE
Circuit-breaker	C	500	17.5-24 kV 16 kA-1 & 3 s 3.6-12 kV 20 kA-1 & 3 s	bolted T-plug	Cu/Al XLPE Cu/Al XLPE



Cones type A
Circuit-breaker 200 A
incl. current transformers



Cones type C
Circuit-breaker 500 A
incl. current transformers



Cones type C
Load-break switch 630 A
without current transformers

Cable connectors

Cable connectors are not included. For 24 kV connections cable connectors with an earthed layer on the outside must be used, for 12 kV connections connectors without an earthed layer might be used also. Both types may not exceed certain dimensions. The cones in the system are according to EN 50181. They can be of the type A (250 A design, panel rating 200 A) and type C (630 A). As an example some possible brands are shown here:

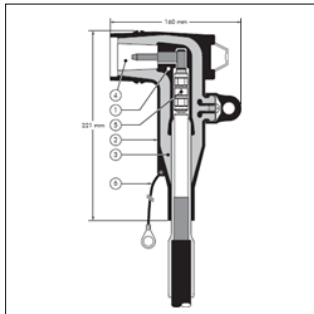

Euromold type K158LR
Xiria circuit-breaker
Cone type A 200 A

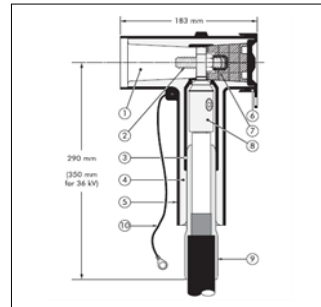

Euromold type K430TB
Xiria circuit-breaker
Cone type C 500 A

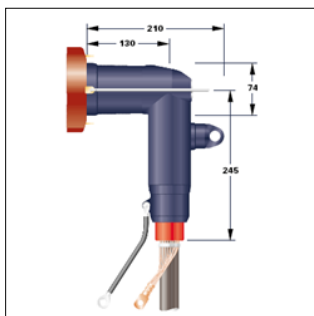

Tyco type RSES
Xiria circuit-breaker
Cone type A 200 A

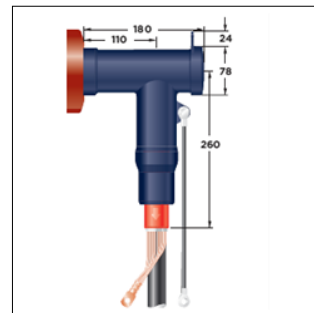

Tyco type RSTI58
Xiria load break switch
Cone type C 630 A

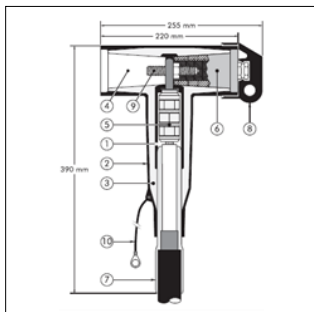

Euromold type K400TB
Xiria load break switch
Cone type C 630 A

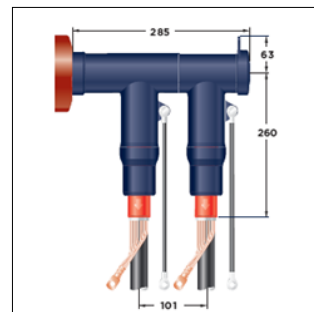

Tyco RSTICC58
Xiria circuit-breaker
Cone type C 500A with double cable for metering
(one primary cable and one cable for a voltage transformer)



Tyco type RICS
Xiria load break switch
Cone type C 630 A

Maximum dimensions for cable connectors inside the Xiria cable compartment

	Panel type		Cable compartment type		Door lock	
			Arc resistant	Non arc resistant	B (mm)	C (mm)
			A (mm)	A (mm)		
Circuit-breaker	200 A	Elbow plug connector type A	238	240	36	37
Circuit-breaker	500 A	Bolted T connector type C	195	197	36	37
Load break switch	630 A	Bolted T connector type C	277	279	36	37

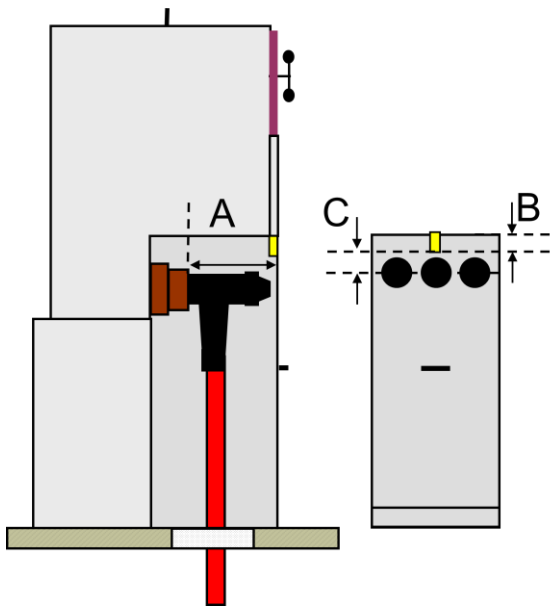

Cable clamps

Cable clamps are included. The cable clamps are mounted on an adjustable frame inside the cable compartment for easy adjustment. The same adjustable frame can be mounted inside the extra plinth too.



Single phase cables

For mounting three single phase cables a panel can be provided with three clamps make KOZ with a diameter of 36-52 or 26-38 mm, suitable for the following max. cable diameters:

Cables	(mm ²)	Ø (mm)
6/10kV	3x1x500	Ø 50
8.7/15kV	3x1x400	Ø 49
18/30kV	3x1x240	Ø 52

Three phase cables

For mounting one three phase cable a panel can be provided with one clamp make KOZ with a diameter of 66-90 or 50-75 mm, suitable for the following cables:

Note: sometimes an extra plinth is necessary due to the height of the cable connection.

XLPE

Cables	(mm ²)	Ø (mm)
6/10kV	1x3x240 CU	Ø 85
8.7/15kV	1x3x240 CU	Ø 91
12/20kV	1x3x185 CU	Ø 90
18/30kV	1x3x150 CU	Ø 99

PILC

Cables	(mm ²)	Ø (mm)
8/10kV	1x3x240	Ø 67
10/10kV	1x3x240	Ø 72
12.5/12.5kV	1x3x185	Ø 74

Maximum torque and weight:

Cable cones type C	max. 70 Nm.
Cable fixing clamps	max. 20 Nm.
Cable weight vertical	max. 450 kg.

Gland plates

The cable compartments can be provided with optional gland plates. With these gland plates the entrance of the primary cables can be closed to avoid the ingress of vermin.

Plinth

If more space is needed for mounting the primary cables each switchboard can be provided with one or two extra steel plinths with a height of 250 mm each. The above mentioned cable clamps can be fitted in the cable compartments or in this plinth.

Cable testing

The various connector suppliers (Euromold, Tyco etc.) can deliver cable-testing accessories. These accessories are designed to be used with the cable connectors of the same brand and type only. The following test voltages can be applied:

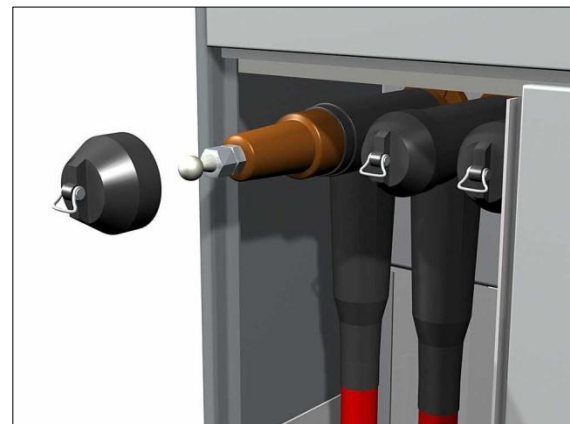

System voltage Test volt. (DC or AC-peak value)

24 kV	60 kV
17.5 kV	45 kV
12 kV	30 kV
7.2 kV	30 kV

10. Applications

The product range comprises load break switches for ring cable connections and circuit-breakers for protected tee-offs. These protected tee-offs can be applied for both the direct protection of transformers as well as the linking up of cable connections with several transformers. Switchboards comprising a combination of two, three, four or five of these panels can be supplied, whereby the panel sequence and combinations can be chosen at will. Consequently, a wide scale of configurations can be installed.

10.1. Examples of applications

Wind turbines

A typical wind turbine connection with a remote controlled circuit-breaker for the generator connection and handoperated load break switches for the ring cable connections.

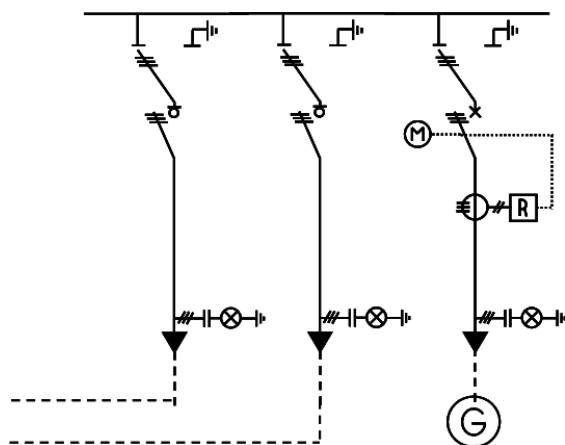

Ring Main Unit

A typical Ring Main Unit connection with hand operated circuit-breakers for one or two transformers and handoperated load break switches for the ring cable connections.

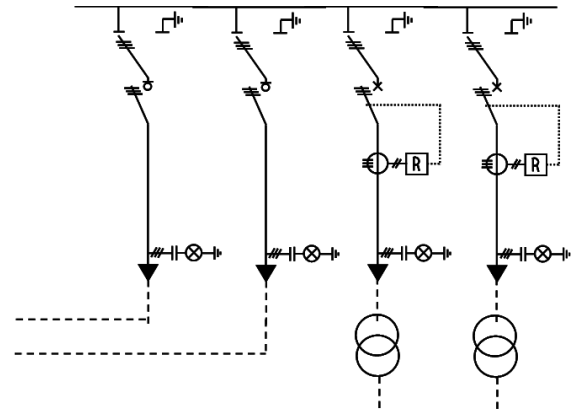

Distribution network

A typical setup for a distribution network with several transformers, energised from the substation.

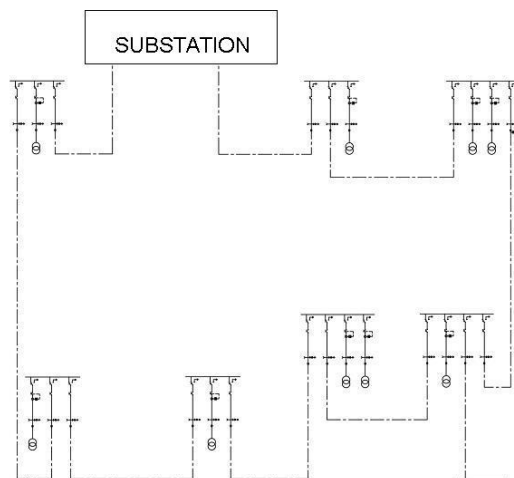

Compact transformer station

A typical compact concrete transformer station with separate compartments for medium voltage (1), the transformer (2) and a low voltage distribution board (3). Cables are connected via a cable cellar.

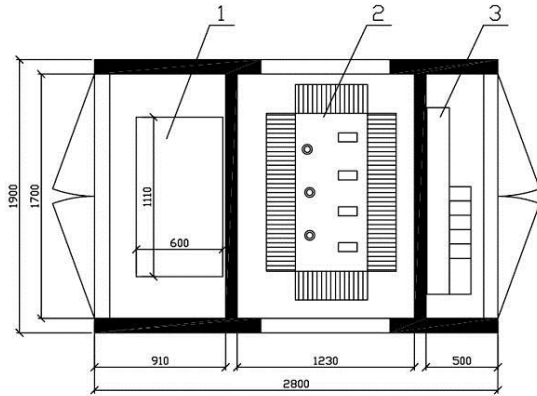

Integrated tariff metering

A typical customer connection with hand operated load break switches for the ring cable connections and a circuit breaker with fully integrated current- and voltage transformers for tariff metering.

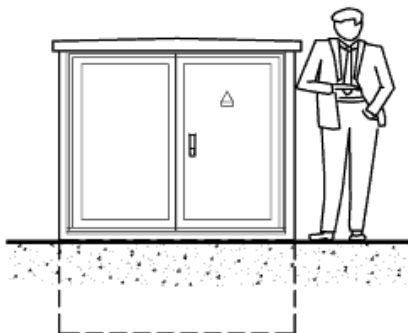
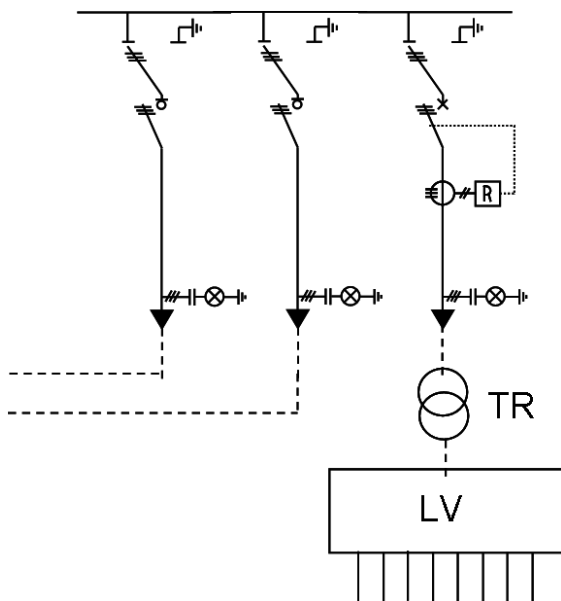
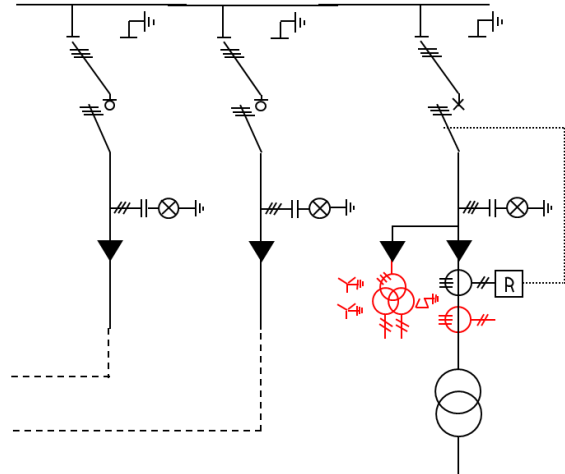

Customer connection distribution network

Typical customer connection in a distribution network with load break switches for the ring cable connections and a circuit breaker connected to the transformer via a separate metering panel with DIN type current- and voltage transformers for tariff metering.

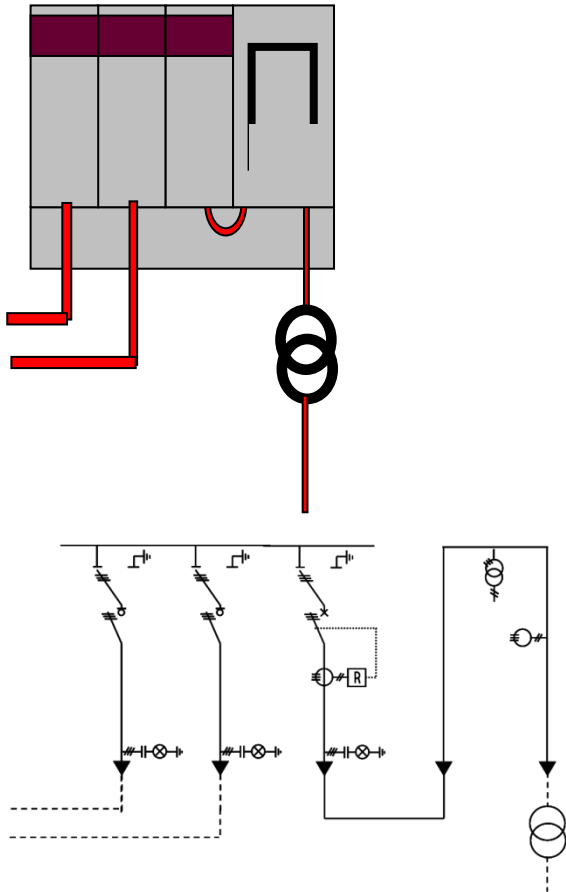



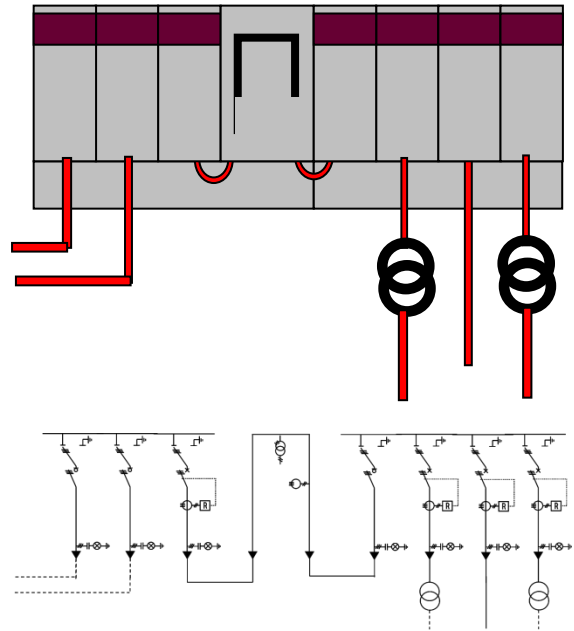

Customer connection for industrial network

Typical customer connection in a industrial distribution network with load break switches for the ring cable connections and a circuit breaker connected to the industrial network with several transformers and cable connections via a separate metering panel with DIN type current- and voltage transformers for tariff and/or control metering.





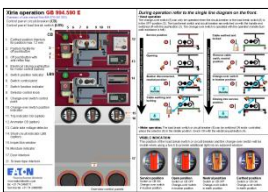



11. Accessories and options

11.1. Accessories

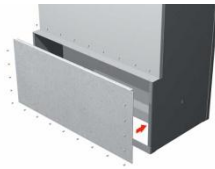
668251	Operating handle 135 mm for ON-OFF switching of the circuit-breaker and the load break switch and for busbar-earth position selection of the change-over switch.	
668270	Operating handle 510 mm Needed for operation of a Xiria unit inside a compact transformer station with limited access in the front area.	
688644	Document holder on the side To store documents and the short operating handle.	
	Quick reference card Showing the basic operations for ON-OFF switching, earthing and testing. Available in multiple languages:	
994.589	Dutch	
994.590	English	
994.591	German	
994.592	French	
994.594	Norwegian	
994.595	Swedish	
994.606	Russian	
994.608	English - ENATS version	
6.015.840	Romanian	
	Operating and maintenance manual Available in multiple languages:	
994.569	Dutch	
994.570	English	
994.586	German	
994.600	Czech	
994.601	Polish	
994.602	French	
994.607	English - ENATS version	
994.610	Russian	
6.021.432	Estonian	
6.044.713	Croatian	

11.2. Options

665417	<p>Scissor type interlock</p> <p>Used in combination with a padlock inserted in the access hole for the vacuum Interrupter. It prevents switching ON and it prevents the operation of the change-over switch.</p>	
107926	<p>Padlock</p> <p>Used in combination with the scissor type interlock and for padlocking the earth interlock on the front.</p>	
107079	<p>Warning sign</p> <p>Used when a panel is switched ON in earthed position and any further manual operation is not allowed.</p>	
Rear cover	<p>Used when the switch room has no rear internal arc exhaust channel.</p>	
E6055889	<p>Adapter WIC1-PC3</p> <p>Used to connect the WIC1-1PE protection relay to a computer (laptop) via a USB connection for setting the protection parameters or retrieving the data stored in the relay memory. Including connection cables and software.</p>	
E6055901	<p>Tester type WIC1-TU</p> <p>Used for on site diagnostic test of the WIC1 protection relay.</p>	
E6046006	<p>Phase sequence indicator type Orion 3.0</p> <p>Used for voltage test, phase sequence test and interface test of the voltage detecting unit type WEGA. The WEGA units are used on Xiria switchgear since December 2009.</p>	
E6046005	<p>Phase sequence indicator type Orion Compare</p> <p>Simplified version of the Orion 3.0. Used for voltage test and phase sequence test of the voltage detecting unit type WEGA. These voltage indication units are used on Xiria switchgear since December 2009.</p>	

11.2. Options

E6046007 Functional tester for WEGA voltage detecting units

The WEGA voltage detection units are used on Xiria switchgear since December 2009.



E6042323 Short circuit indicator type SIGMA

It detects short-circuit currents in medium-voltage distribution networks. It consists of a display unit accommodated in a plug-in housing for panel mounting and three current transformers for short circuit sensing.



668002 Short circuit indicator type ALPHA-M

It detects short-circuit currents in medium-voltage distribution networks. It consists of a display unit accommodated in a plug-in housing for panel mounting and three current transformers for short circuit sensing. The ALPHA-M unit is provided with a small mechanical generator on the front to reset and test the short circuit indication.



Cable fixing clamps for primary cables

- 665868** 36 - 52 mm single phase cables.
- 665997** 26 - 38 mm single phase cables.
- 665867** 66 - 90 mm three phase cables.



Voltage detector with LCD screen make Horstmann type WEGA 1.2

- E6015230** 3 - 4.15 kV
- E6015231** 6 - 7.2 kV
- E6015232** 10 - 15 kV
- E6015233** 17.5 - 24 kV



Voltage detector with LCD screen make Horstmann type WEGA 2.2

Equal to the 1.2 version, however including aux.voltage connection and signalling contacts.



6038501 Mounting plate

For mounting a WEGA detector in existing front panel with legacy LED indication.



Ammeter make ELEQ with current transformer in phase L2 in cable compartment (on circuit-breaker only)



11.2. Options

<p>E665245 E665246</p>	<p>Trip indicator (for circuit-breaker only) SZ4H without aux. contact. SZ5H with aux. contact.</p>	
<p>E665258</p>	<p>Protection relay make Woodward SEG type WIC1-1PE Setting via adapter for computer connection.</p>	
<p>E569882</p>	<p>Protection relay make Woodward SEG type WIC1-2PE Setting via DIP switches on the front.</p>	
<p>E569884</p>	<p>Protection relay make Woodward SEG type WIC1-3PE Setting via HEX switches on the front.</p>	
<p>E6056904</p>	<p>Protection relay make Woodward SEG type WIB1-2PE Setting via DIP switches on the front.</p>	
<p>E6031210</p>	<p>Protection device type TLF (Time Limit Fuse protection) Setting via LV fuses on the front. Fuses are make GE Power Controls type XF (excluding fuses).</p>	

11.2. Options

Current transformers for WIC1 and WIB1 protection relays

E6056903	WE1H1	Around the primary cables	WIC1 8-28A	WIB1 8-15A
E665267	WE2H1	On cone type A	WIC1 16-56A	WIB1 16-30A
E665251	W3H1	On cone type A	WIC1 32-112A	WIB1 32-60A
E665252	W4H1	On cone type A	WIC1 64-224A	WIB1 64-120A
E665253	W5H1	On cone type A	WIC1 128-448A	WIB1 128-240A
E6014721	WE2H3	On cone type C	WIC1 16-56A	WIB1 16-30A
E6014719	W3H3	On cone type C	WIC1 32-112A	WIB1 32-60A
E6014720	W4H3	On cone type C	WIC1 64-224A	WIB1 64-120A
E6015274	W5H3	On cone type C	WIC1 128-448A	WIB1 128-240A

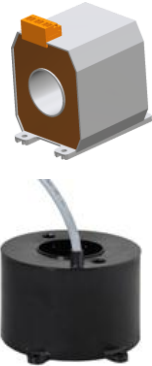

11.3. Legacy options (still available)

612441 Piezo tester type CL

Used for legacy voltage detection units with LED type voltage detection type JB. Production of these voltage detectors has been stopped end 2009.



E569987 Phase sequence indicator type SPC6000

Used for legacy voltage detection units with LED type voltage detection type JB. Production of these voltage detectors has been stopped end 2009.



12. Maintenance

The Xiria unit is designed as a maintenance-free system. No specific components need to be maintained. All the live primary parts and mechanisms in a Xiria unit are installed in a fully enclosed housing. This prevents dust, moisture and other environmental influences from affecting the operation of the unit. The switching mechanism has been designed with a minimum number of parts, and is specifically intended for switching after a long period of inactivity. This mechanism does not use any lubricants, which also benefits its operational safety. All other components have also been designed to be maintenance free.

The following components can be inspected:

- Correct fixing of cable and earth connections;
- Enclosure for damage and contamination;
- Protection relay;
- Switching functions;
- Voltage detection;
- Over current indicator.

As it is maintenance free, Xiria significantly cuts inspection and maintenance costs without adversely affecting the operational safety of the distribution network.

13

13. Quality

Eaton has been meeting the ISO 9001 quality assurance requirements since 1989. This quality assurance system calls for a periodic evaluation of the organizational structure, the assignment of responsibilities and the associated procedures. It also guarantees corrective action and activities when required. This keeps the quality assurance system up to standard and enables adjustments to be made and further development to take place where necessary.

Xiria switchgear is manufactured and tested in accordance with the procedures as laid down in ISO 9001-2000. KEMA Registered Quality B.V. checks periodically that these standards are adhered to. In addition, with respect to its integral environmental management system, Eaton Electric B.V. adheres to ISO 14001.

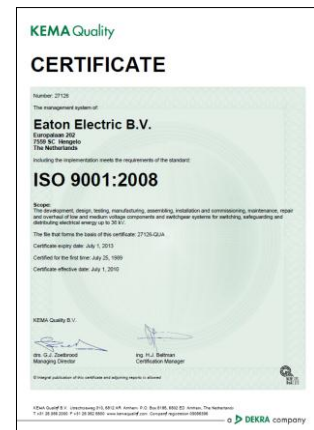

EAT•N



EAT•N

Powering Business Worldwide

There's a certain energy at Eaton. It's the power of uniting some of the world's most respected names to build a brand you can trust to meet every power management need. The energy created supports our commitment to powering business worldwide.

From power distribution to power quality and control, Eaton allows you to proactively manage your complete power system by providing electrical solutions that make your applications safer, more reliable, and highly efficient. Visit www.eaton.com/electrical.

All of the above are trademarks of Eaton Corporation or its affiliates. *Eaton has a license to use the Westinghouse brand name in Asia Pacific. ©2009 Eaton Corporation.

Eaton's Electrical Sector is a global leader in power distribution, power quality, control and automation, and monitoring products. When combined with Eaton's full-scale engineering services, these products provide customer-driven PowerChain® solutions to serve the power system needs of the data center, industrial, institutional, public sector, utility, commercial, residential, IT, mission critical, alternative energy and OEM markets worldwide.

PowerChain Management solutions help enterprises achieve sustainable and competitive advantages through proactive management of the power system as a strategic, integrated asset throughout its life cycle, resulting in enhanced safety, greater reliability and energy efficiency.

For more information, visit www.eaton.com/electrical.

PowerChain® solutions help enterprises achieve sustainable and competitive advantages through proactive management of the power system as a strategic, integrated asset throughout its life cycle, resulting in enhanced safety, greater reliability and energy efficiency. For more information, visit www.eaton.com/electrical.

Eaton Industries (Netherlands) B.V.
P.O. Box 23
7550 AA Hengelo
The Netherlands

Tel.: +31 (0)74 - 246 40 10
Fax: +31 (0)74 - 246 40 25
info.electric@eaton.com
www.eatonelectric.com

© 2011 Eaton Industries (Netherlands) B.V.
All rights reserved.

Issue number: 605 6243 G01 02
Date: 07-06-2011